

TSMNA25 Series Linear Actuators



FEATURES

- **Competitively priced, high resolution digital non-captive linear actuators**
- **Linear force up to 6.75 lbs (30N)**
- **Linear step resolution of .001", .002" and .004"**
- **Unipolar and bipolar coil constructions**
- **Fast, powerful and precise positioning**
- **Precision radial ball bearing design**
- **Industry standard frame size**
- **Customized designs available**
- **CE Certified and RoHS Compliant**



DESCRIPTION

The TSMNA25 Series Non-Captive Linear Actuators are the perfect choice for cost effective linear motion. The stepper motor internally converts rotary motion to linear motion via a rotating nut and a leadscrew. This actuator eliminates the need for other rotary-to-linear conversions such as belt and pulleys, rack and pinions, or external ball screws. Motion designs can be simplified, production costs lowered and product life enhanced. The motors can be customized to fit your machine requirements. The motor comes in a standard 6-lead configuration and is available in a 4-lead configuration. We can also customize the winding to perfectly match your voltage, current, and maximum operating speed. Special screw modifications, cables and connectors are also available upon request.

SPECIFICATIONS

Model #	Rated Voltage (V)	Travel Per Step (mm)	The Mark Thrust (N)	The Mark Pull (N)	Resistance Per Phase (ohm)	Inductance Per Phase (mh)	Current Per Phase (A)	Weight (oz)
TSMNA25-150-17-023-L004	12	0.0417	34	34	53	23.5	0.23	1.66

L010590

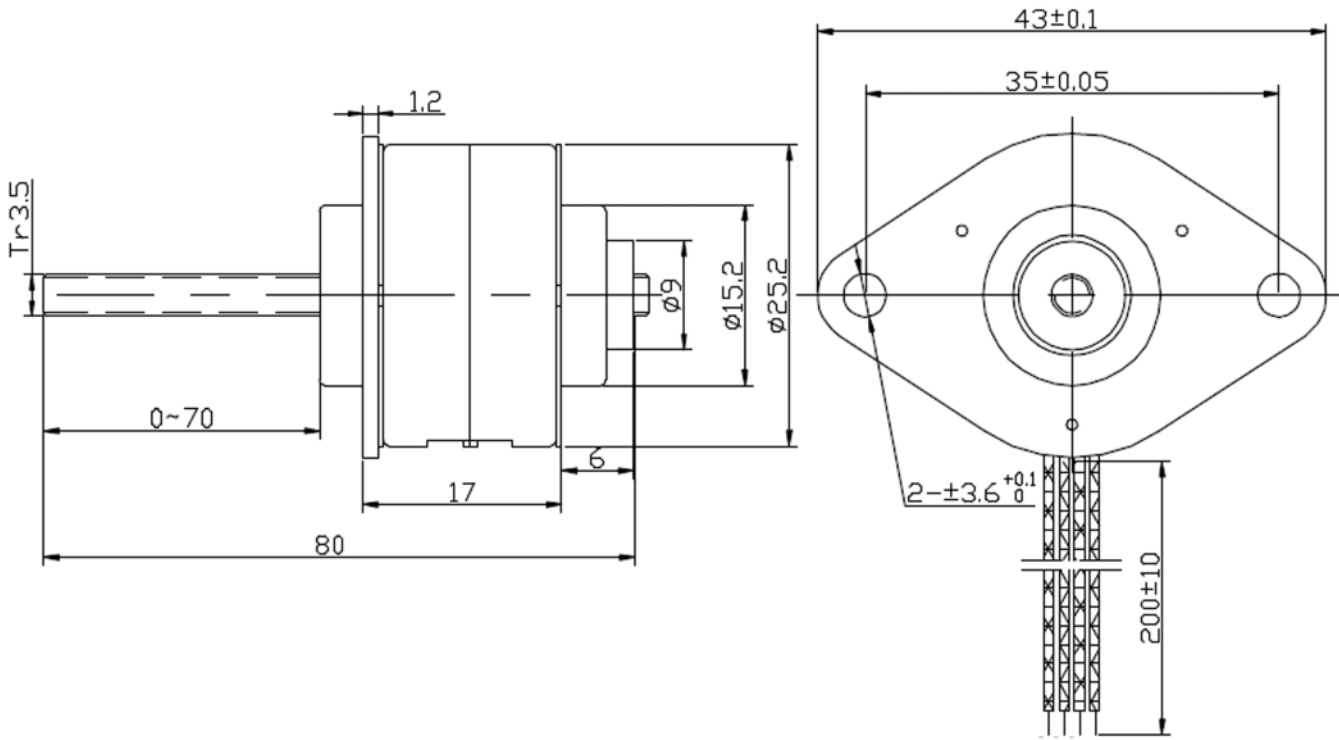

DIMENSION

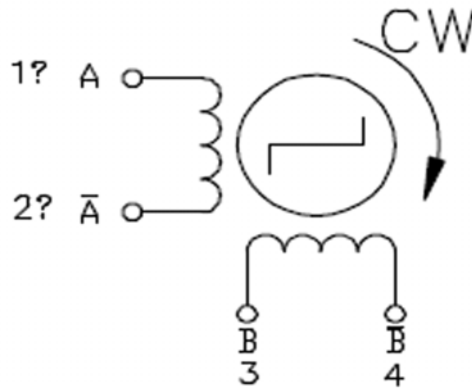

WIRING INFORMATION

Number of Phase:	2-Phase
Insulation Resistance:	100 M-ohms
Min Working Voltage:	6V
Protection Rate:	IP34
Operating Temperature Range:	-40°C to 125°C

SPECIFICATIONS